

6

ಒಟ್ಟು ಮುದ್ರಿತ ಪುಟಗಳ ಸಂಖ್ಯೆ : 16]

Total No. of Printed Pages : 16]

ಒಟ್ಟು ಪ್ರಶ್ನೆಗಳ ಸಂಖ್ಯೆ : 38]

Total No. of Questions : 38]

ಸಂಕೇತ ಸಂಖ್ಯೆ : **81-E**

Code No. : **81-E**

A

**CCE RR
UNREVISED
FULL SYLLABUS**

Question Paper Serial No. **210**

ವಿಷಯ : ಗಣಿತ

Subject : MATHEMATICS

(ಇಂಗ್ಲಿಷ್ ಮಾಧ್ಯಮ / English Medium)

(ಪುನರಾವರ್ತಿತ ಶಾಲಾ ಅಭ್ಯರ್ಥಿ / Regular Repeater)

ದಿನಾಂಕ : 17. 06. 2023]

[Date : 17. 06. 2023

ಸಮಯ : ಬೆಳಿಗ್ಗೆ 10-30 ರಿಂದ ಮಧ್ಯಾಹ್ನ-1-45 ರವರೆಗೆ]

[Time : 10-30 A.M. to 1-45 P.M.

ಗರಿಷ್ಠ ಅಂಕಗಳು : 80]

[Max. Marks : 80

General Instructions to the Candidate :

1. This question paper consists of objective and subjective types of 38 questions.
2. This question paper has been sealed by reverse jacket. You have to cut on the right side to open the paper at the time of commencement of the examination. Check whether all the pages of the question paper are intact.
3. Follow the instructions given against both the objective and subjective types of questions.
4. Figures in the right hand margin indicate maximum marks for the questions.
5. The maximum time to answer the paper is given at the top of the question paper. It includes 15 minutes for reading the question paper.

RR-A(210)1042

[Turn over

ಇಲ್ಲಿಂದ ಕತ್ತರಿಸಿ

TEAR HERE TO OPEN THE QUESTION PAPER

ಪ್ರಶ್ನೆಪತ್ರವನ್ನು ತೆರೆದಿ ಇಲ್ಲಿ ಕತ್ತರಿಸಿ

Tear here

- I. **Four alternatives are given for each of the following questions / incomplete statements. Choose the correct alternative and write the complete answer along with its letter of alphabet. $8 \times 1 = 8$**



1. The H.C.F. of any two prime numbers is

(A) 0

(B) 2



(C) 1

(D) - 1

2. The degree of the polynomial $P(x) = 3x^3 - 8x^2 + 6x - 3$ is

(A) 3

(B) 2



(C) 1

(D) 0

3. The coordinates of the midpoint of the line segment joining the points (3, 4) and (5, 6) is

(A) (-4, -5)

(B) (4, 5)



(C) (4, -5)

(D) (-4, 5)

4. The probability of winning a game is $\frac{3}{4}$. The probability of losing the same game is

(A) $\frac{1}{2}$

(B) $\frac{3}{4}$

(C) $-\frac{1}{4}$

(D) $\frac{1}{4}$



5. In triangle ABC if $DE \parallel BC$, then the correct relation among the following is,

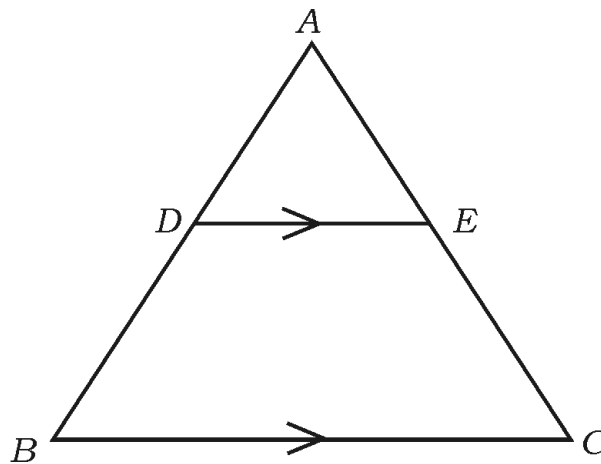

(A) $\frac{AD}{BD} = \frac{AE}{EC}$

(B) $\frac{AB}{AD} = \frac{EC}{BD}$

(C) $\frac{AD}{AE} = \frac{CE}{BD}$

(D) $\frac{DE}{BC} = \frac{AE}{AD}$



6. The distance between two parallel tangents in a circle of radius 3 cm is



- (A) 3 cm (B) 1.5 cm
(C) 9 cm (D) 6 cm



7. The formula to find the volume of a solid cylinder having base radius ' r ' and height ' h ' is



- (A) $V = 4\pi r^2$ (B) $V = \pi r^2 h$
(C) $V = \pi r l$ (D) $V = \frac{1}{3} \pi r^2 h$

8. If the n^{th} term of an arithmetic progression is $a_n = 2n + 1$ then its $(n - 1)^{\text{th}}$ term is



- (A) $(2n - 2)$ (B) $(2n + 3)$
(C) $(2n - 1)$ (D) $2n$



II. Answer the following questions :

**8 × 1 = 8**

9. According to Euclid's division lemma, if $13 = 4 \times 3 + r$, then find the value of 'r'.

10. How many solutions do the pair of linear equations $x + 2y - 4 = 0$ and $3x + 2y - 5 = 0$ have ?



11. If $x, 7, 10 \dots$ are in arithmetic progression then write the value of x .

12. Find the sum of the zeroes of the polynomial $P(x) = x^2 - 5x + 6$.

13. Find the value of the discriminant of the quadratic equation

$$x^2 - 5x + 1 = 0.$$



14. Write the formula to find the area of triangle PQR having vertices

$$P(x_1, y_1), Q(x_2, y_2) \text{ and } R(x_3, y_3).$$



15. In the figure, name the side of triangle PQR which is corresponding to the side AB of triangle ABC .

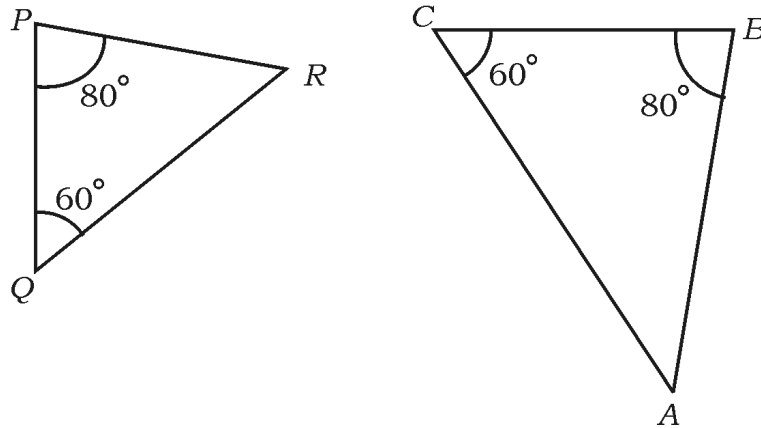

16. Write the formula to find the surface area of a sphere having radius ' r ' units.



III. Answer the following questions :

$8 \times 2 = 16$

17. Prove that $2 + \sqrt{3}$ is an irrational number.



OR

Show that the rational number $\frac{29}{147}$ has non-terminating

decimal expansion without performing long division.



18. Find the solution for the given pair of linear equations :

$$x + y = 10$$



$$2x - y = 8$$



19. Find the 21st term of the arithmetic progression 5, 9, 13, by using formula.

20. Find the roots of the equation $x^2 - 3x + 1 = 0$ using quadratic

formula.



OR

Solve the equation $x^2 - 3x - 10 = 0$ by completing the square method.



21. In the given figure, find the values of $\cos \alpha$ and $\tan \theta$.

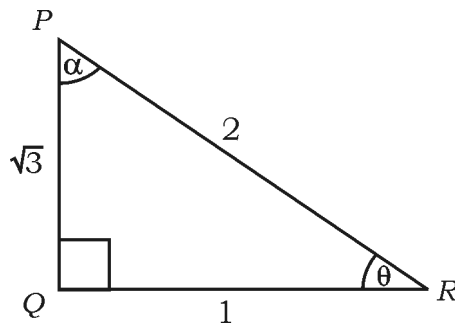

22. A box consists of 9 cards which are numbered from 10 to 18. If one card is drawn at random from the box then find the probability of getting a prime number.



23. In triangle ABC , $\angle ABC = 90^\circ$ and D is the midpoint of BC . Prove that $AC^2 = AD^2 + 3CD^2$.

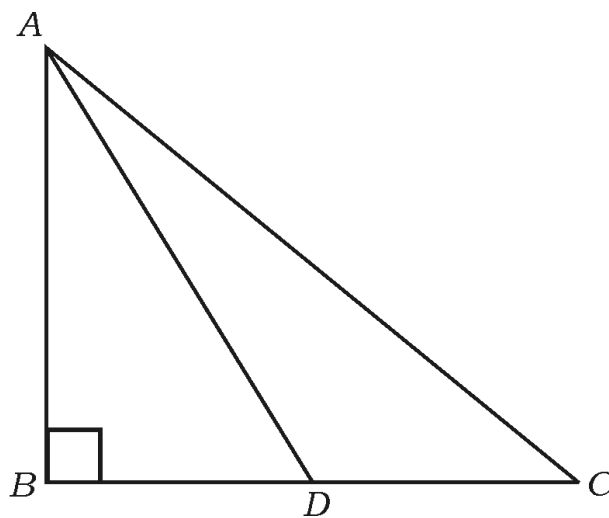

24. Construct two tangents to a circle of radius 3 cm from a point 7 cm away from its centre.



IV. Answer the following questions :

9 × 3 = 27

25. Find the sum of the first 40 positive integers divisible by 6.



OR

The second and third terms of an arithmetic progression are 14 and 18 respectively. Find the sum of the first 26 terms of the Arithmetic progression using the formula.



26. Divide $P(x) = x^3 - 3x^2 + 5x - 3$ by $g(x) = x^2 - x + 1$, then find the quotient $q(x)$ and remainder $r(x)$.
27. Prove that $(\sec A - \cos A)(\cot A + \tan A) = \tan A \cdot \sec A$.



OR

If A, B and C are interior angles of a triangle then prove that

$$1 + \tan^2 \left(\frac{A+B}{2} \right) = \operatorname{cosec}^2 \left(\frac{C}{2} \right).$$



28. The points A, B and C are collinear. If $A(1, 0)$, $B(4, 4)$ and $AC = 8$ cm, then find the coordinates of point C .

29. Calculate the mean for the data in the following frequency

distribution table :



<i>Class-interval</i>	<i>Frequency (f_i)</i>
5 – 15	4
15 – 25	6
25 – 35	5
35 – 45	6
45 – 55	4
	$\Sigma f_i = 25$



OR

Calculate the mode for the data in the following frequency

distribution table :

<i>Class-interval</i>	<i>Frequency</i>
10 – 15	3
15 – 20	3
20 – 25	7
25 – 30	6
30 – 35	6



30. The daily income of 50 workers of a factory were recorded as follows. Draw “less than type” ogive for the given data.



<i>Daily income in Rs.</i>	<i>Number of workers (cumulative frequency)</i>
Less than 100	10
Less than 120	25
Less than 140	35
Less than 160	40
Less than 180	50



31. Prove that “The tangent at any point of a circle is perpendicular to the radius through the point of contact”.



32. Construct a triangle with sides 5 cm, 6 cm and 8 cm. Then construct another triangle whose sides are $\frac{3}{4}$ of the corresponding sides of the first triangle.



33. The sides of a square touch the circle of radius ' r ' as shown in the figure. If the area of the shaded region is 42 cm^2 then find the radius of the circle.

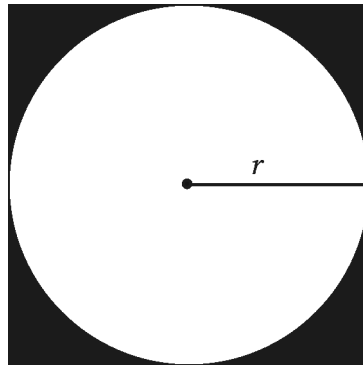

OR

- In the figure the area of the sector OAB is 231 cm^2 and length of the arc AB is 22 cm . Find the radius of the sector.

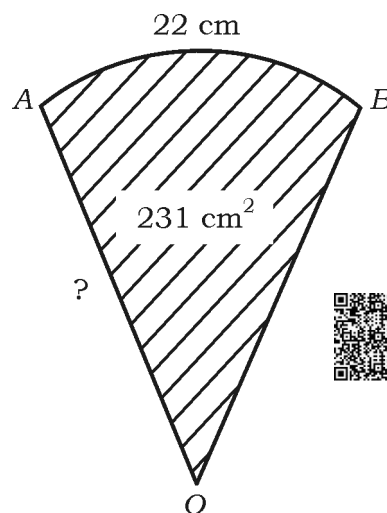

V. Answer the following questions :



4 × 4 = 16

34. Find the solution of the given pair of linear equations by

graphical method :



$$x + y = 5$$



$$2x + y = 6$$

35. The denominator of a fraction is 3 more than its numerator. If the

sum of this fraction and its reciprocal is $\frac{29}{10}$ then find the



fraction.

OR

A student bought some books for Rs. 60. Had he bought 5 more

books for the same amount each book would have cost him Re. 1

less. Find the number of books bought by him.





36. A 1.2 m tall girl spots a balloon moving with the wind in a horizontal line at a height of 88.2 m from the ground. The angle of elevation of the balloon from the eyes of the girl at any instant is 60° . After some time the angle of elevation reduces to 30° (see the figure). Find the distance travelled by the balloon during the interval.

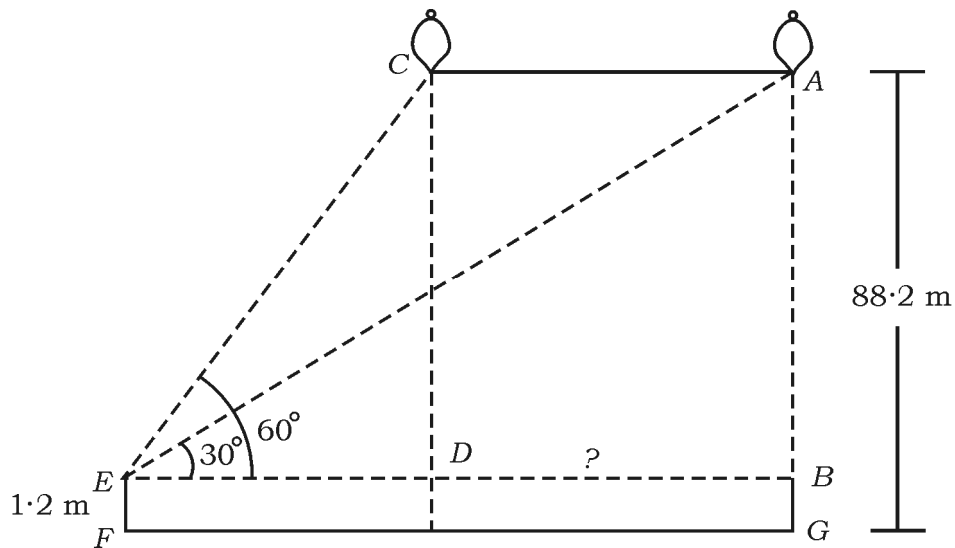

37. Prove that “The ratio of the areas of two similar triangles is equal to the square of the ratio of their corresponding sides”.



VI. Answer the following question :



$1 \times 5 = 5$



38. A dustbin in the form of a frustum of a cone is mounted on the circular base of a hollow cylinder as shown in the figure. The radii of circular top and bottom of the dustbin and its slant height are 18 cm, 8 cm and 26 cm respectively. The radius and height of the cylinder are 8 cm and 6 cm respectively. If the total height of the given solid is 30 cm, then find the volume of the dustbin and also the curved surface area of the entire solid.

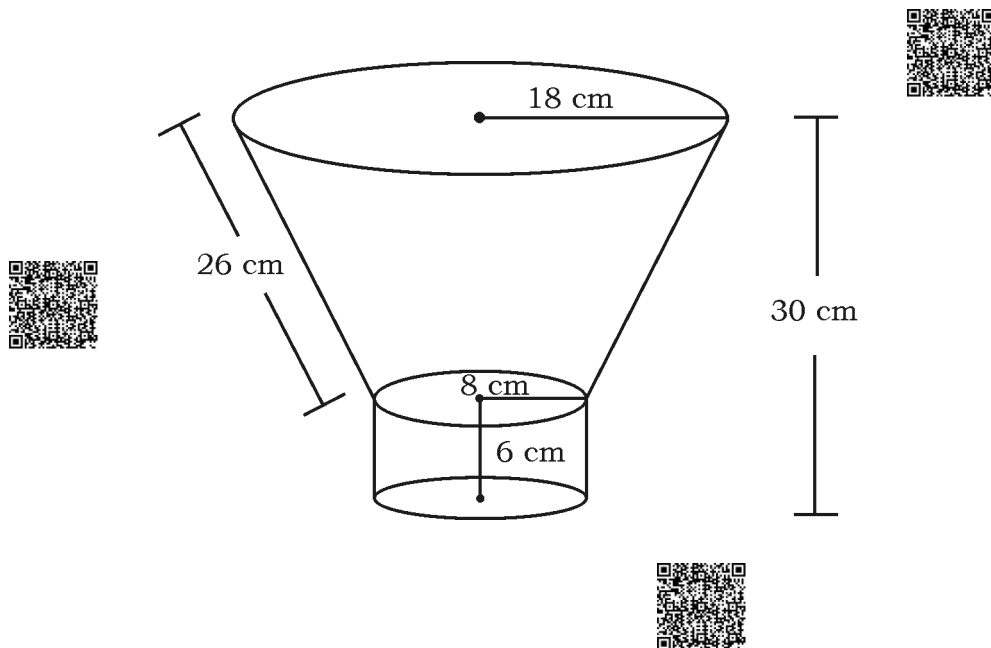

81-E

16

CCE RR

RR-A(210)1042

6